

Test report # PF21046

Test Number 21046

Client: RLA Polymers Pty Ltd

Fire resistance tests for wall penetrations

Test method: AS 1530.4:2014

Report Date 11/09/2021

1. Table of Contents

1.	Table of Contents	2
1.1	Document revision schedule	3
1.2	Signatories	3
2.	Contact details.....	4
2.1	IANZ registered Testing Authority	4
2.2	Client/Applicant.....	4
2.3	Manufacturer.....	4
3.	Test Results	5
4.	Test Details.....	6
5.	Equipment.....	8
6.	Test Conditions.....	9
6.1	Furnace Temperature	9
6.2	Ambient Temperature	9
6.3	Pressure Readings.....	10
7.	Schedule of materials.....	11
8.	Test Specimens details	13
8.1	Thermocouple Positions Table	13
8.2	Observations.....	15
9.	Separating element and main fire-stopping system.....	17
10.	Specimens	19
10.1	Specimen A	20
10.2	Specimen B	22
10.3	Specimen C	24
10.4	Specimen D.....	26
11.	Additional photographs.....	29
11.1	Materials used	29
11.2	During and after the test	30

1.1 Document revision schedule

Revision #	Date	Description
1	29/08/2021	Initial Issue for Client review
2	11/09/2021	Issued for Client review

1.2 Signatories

Report	Name	Signature	Date
Prepared by:	Alexey Kokorin (Technical Manager)		11/09/2021
Authorized by:	Andrew Bain (Authorized signatory)		11/09/2021



All tests reported herein have been performed in accordance with the laboratory's scope of accreditation

2. Contact details

2.1 IANZ registered Testing Authority

Passive Fire Inspection and Test Services Ltd

Accreditation N^o: 1335

1/113 Pavilion Drive, Mangere, Auckland, 2022

New Zealand

Contact e-mail: tests@firelab.co.nz

2.2 Client/Applicant

RLA Polymers Pty Ltd

215 Colchester Road, Kilsyth, Victoria, 3137

Australia

Contact e-mail: hildebrand@rlapolymers.com.au

2.3 Manufacturer

RLA Polymers Pty Ltd

215 Colchester Road, Kilsyth, Victoria, 3137

Australia

3. Test Results

Specimen #	Service/Joint	Actual Integrity (min)	Actual insulation (min)	FRL*
A	40mm horizontal linear joint	360 NF	360 NF	-/360/360
B	50mm vertical linear joint	360 NF	360 NF	-/360/360
C	30mm vertical linear joint with stich plate	360 NF	360 NF	-/360/360
D	40DN Steel Pipe	360 NF	360 NF	-/360/360

NF – No failure during the test

This report shall not be reproduced, except in full.

The test results relate to the specimens of the product in the form in which they were tested. Differences in the composition or thickness of the product may significantly affect the performance during the test and may therefore invalidate the test results. Care should be taken to ensure that any product, which is supplied or used, is fully represented by the specimens, which were tested.

The specimens were supplied by the sponsor and the Laboratory was not involved in any of selection or sampling procedures.

The results of these fire tests may be used to directly assess fire hazard, but it should be recognized that a single test method will not provide a full assessment of fire hazard under all fire conditions.

4. Test Details

Test Specification Fire Resistance:

Failure shall be deemed to have occurred when one of the following occurs:

- a) the temperature at any location on the unexposed face of the test specimen exceeds the initial temperature by more than 180 °C
- b) Integrity failure shall be deemed to have occurred upon ignition of the cotton pad when glowing or flaming occurs for a period of 30 seconds.
- c) Flaming to the unexposed face for 10 seconds or longer shall be deemed to be an Integrity failure.
- d) Integrity failure shall be deemed to occur when a 6mm gap gauge can be passed through the specimen so that the gap gauge projects into the furnace and can be moved a distance of 150mm along the gap.
- e) Integrity failure shall be deemed to occur when a 25mm gap gauge can be passed through the specimen so that the gap gauge projects into the furnace

Testing scope:

AS 1530-2014 Part 4 Section 10 Service penetrations and control joints

AS 4072.1-2005 Part 1 Appendix A - Typical examples of fire-stopping systems for movement joints.

Documentation:

Testing products were verified and tested based on Client description, refer to Specimens description below. All drawings were provided by Client, in case of any difference between the drawings and report description, the text description shall prevail.

Testing date:

06/08/2021

Installation completion date:

22/07/2021

Specimens conditioning and delivery to Laboratory:

Separating element was built by Laboratory in line with Client instructions. Installation of fire stopping system was performed by Client. The Laboratory was not involved in sampling of the materials. Laboratory verified materials during construction of the specimen.

Termination of The Test:

The test was discontinued at 360 minutes.

Use of Reports:

This report shall not be reproduced, except in full.

This report details the methods of construction, test conditions and the results obtained when the specific element of construction described herein was tested following the procedure outlined in AS 1530.4. Any significant variation with respect to size, constructional details, loads, stresses, edge or end conditions, other than that allowed under the field of direct application in the relevant test method, is not covered by this report.

Because of the nature of fire resistance testing and the consequent difficulty in quantifying the uncertainty of measurement of fire resistance, it is not possible to provide a stated degree of accuracy of the result.

5. Equipment

Furnace:

1200X1200 Indicative Furnace designed to operate to AS1530.4:2014

Temperature:

Furnace Temperature measurements were controlled with four 3mm Type K MIMS thermocouples set within 50-100 mm from the face of the specimens in line with AS1530.4-2014. All thermocouples are calibrated by ISO/IEC 17025 accredited laboratory - a signatory to the International Laboratory Accreditation Corporation (ILAC) through their Mutual Recognition Agreement (MRA) to the accuracy required by AS 1530.4-2014.

Pressure measurement:

Kepware Siemens Data logging system including multi-channel recording data at 5 second intervals. Calibrated by ISO/IEC 17025 accredited laboratory - a signatory to the International Laboratory Accreditation Corporation (ILAC) through their Mutual Recognition Agreement (MRA) to the accuracy required by AS 1530.4-2014.

Ambient Temperature:

Ambient temperature was recorded 15 minutes before the test was commenced, at the start of the test and monitored during the test. All thermocouples are calibrated by ISO/IEC 17025 accredited laboratory - a signatory to the International Laboratory Accreditation Corporation (ILAC) through their Mutual Recognition Agreement (MRA) to the accuracy required by AS 1530.4-2014.

Specimen thermocouples:

Specimen thermocouples were installed to the unexposed face. Type K copper disk thermocouples fixed within the required locations referenced from AS1530.4-2014. Thermocouples are calibrated by ISO/IEC 17025 accredited laboratory - a signatory to the International Laboratory Accreditation Corporation (ILAC) through their Mutual Recognition Agreement (MRA) to the accuracy required by AS 1530.4-2014.

Dimensional measurements:

All linear measurements are made with equipment calibrated by ISO/IEC 17025 accredited laboratory - a signatory to the International Laboratory Accreditation Corporation (ILAC) through their Mutual Recognition Agreement (MRA) to the accuracy required by AS 1530.4-2014.

6. Test Conditions

6.1 Furnace Temperature

The furnace was controlled to follow the temperature/time relationship specified in AS 1530.4-2014 as closely as possible.

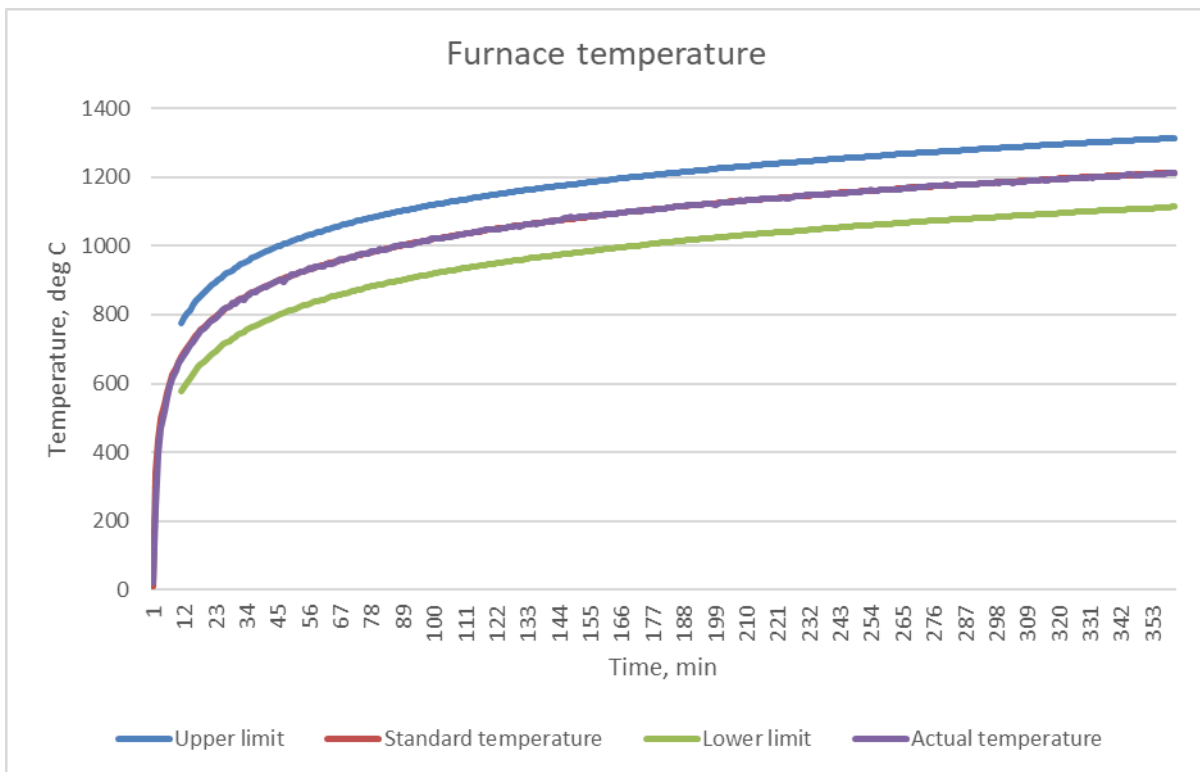

6.2 Ambient Temperature

The ambient temperature of the test area 15 minutes before the test and at the commencement of the test was 15 °C.

6.3 Pressure Readings

The furnace pressure was maintained at 16 ± 3 Pa with respect to atmosphere. The probe was located 500mm above the furnace floor.

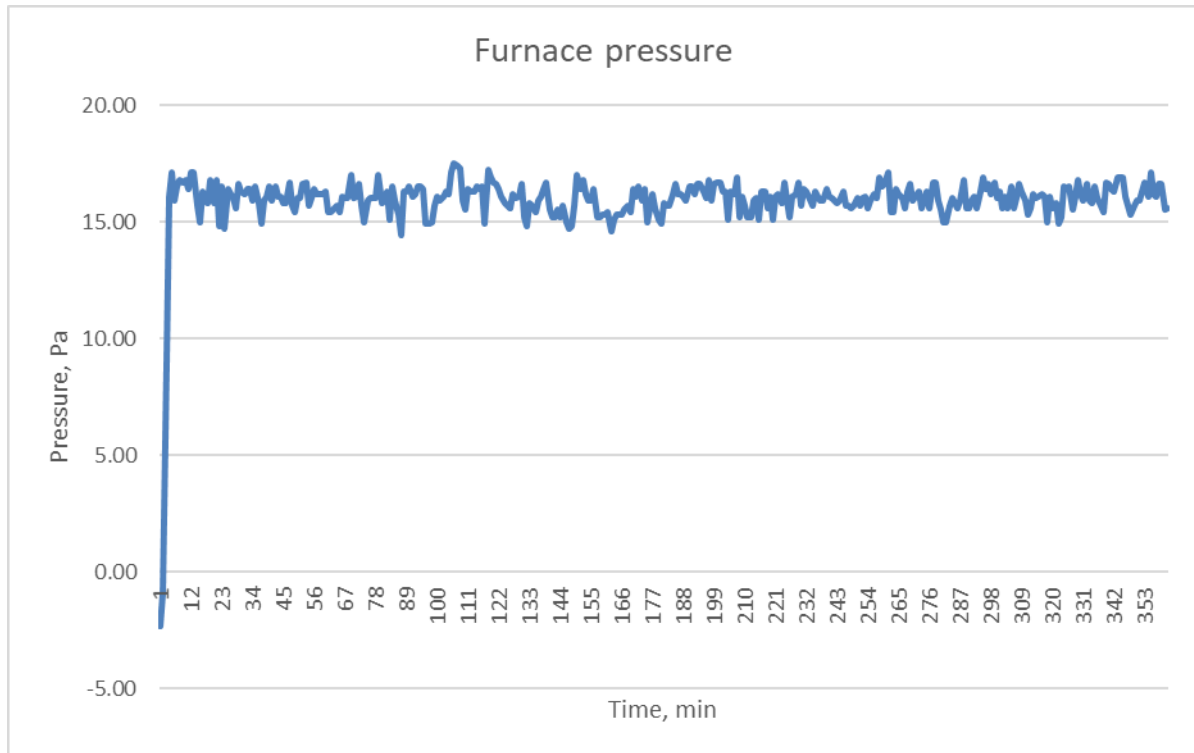

7. Schedule of materials

All firestopping products were supplied and installed by Client.

Separating Element		
1.1	Item / Product Name	Concrete Slab Separating element
	Measurements	Width / Height (W/H): 1200mm x 1200mm
		Thickness (T): 180mm
1.2	Item / Product Name	Concrete Lintel
	Measurements	Width / Height (W/H): 1200mm x 160mm
		Thickness (T): 300mm
	Additional Info	Used to form separating element
1.3	Item / Product Name	Concrete Slab 1
	Measurements	Width / Height (W/H): 200mm x 1000mm
		Thickness (T): 180mm
	Additional Info	Used to form separating element
1.4	Item / Product Name	Concrete Slab 2
	Measurements	Width / Height (W/H): 535mm x 1000mm
		Thickness (T): 180mm
	Additional Info	Used to form separating element
1.5	Item / Product Name	Concrete Slab 3
	Measurements	Width / Height (W/H): 380mm x 1000mm
		Thickness (T): 180mm
	Additional Info	Used to form separating element
1.6	Item / Product Name	Steel Stitch Plate
	Measurements	Width / Height (W/H): 400mm x 300mm
		Thickness (T): 10mm

	Additional Info	Used to form separating element
--	-----------------	---------------------------------

Services		
2.1	Item / Product Name	40DN Steel Pipe
	Measurements	Inner Diameter (ID): 41.73mm
		Outer Diameter (OD): 48.26mm
		Thickness (T): 3.11mm
Additional Info	Specimen D	

Sealants		
3.1	Item / Product Name	RLA FirePro Sealant
	Measurements	600mL Sausage
	Installation	Used to seal aperture gaps of services
3.2	Item / Product Name	RLA Penapatch LW Repair Mortar
	Measurements	20kg Bag
	Installation	Used to fill stitch plate cavity

Fixings		
4.3	Item / Product Name	Stainless Steel Cable Ties
	Measurements	4.6 x 200mm
	Installation	Used to fix wrap to services

Fire Stopping Materials		
5.1	Item / Product Name	Superwool Plus Ceramic Fibre Blanket
	Measurements	Width / Height (W/H): 610mm x 14640mm
		Thickness (T): 13mm
		Density (ρ): 128kg/m ³
Installation	Wrapped around services	

8. Test Specimens details

8.1 Thermocouple Positions Table

SPECIMEN	TC#	THERMOCOUPLE LOCATION DESCRIPTION
A	1	Separating element, on bottom face of concrete lintel, in-line with Specimen B, 25mm from gap seal
A	2	Separating element, on bottom face of concrete lintel, mid-width of separating element, 25mm from gap seal
A	3	Separating element, on bottom face of concrete lintel, in-line with Specimen C, 25mm from gap seal
A	4	Gap seal, mid-height of the gap seal, in-line with Specimen B
A	5	Gap seal, mid-height of the gap seal, mid-width of separating element
A	6	Gap seal, mid-height of the gap seal, in-line with Specimen C
B	7	Gap seal, mid-width of the gap seal, 50mm below the top of the concrete slabs
B	8	Gap seal, mid-width of the gap seal, mid-height of the gap seal
B	9	Gap seal, mid-width of the gap seal, 100mm above the bottom of the concrete slabs
C	10	Gap seal, mid-width of the gap seal, 50mm below the top of the concrete slabs
C	11	Gap seal, mid-width of the gap seal, 50mm above stitch plate
C	12	Gap seal, mid-width of the gap seal, 50mm below stitch plate
B/A	13	Separating element, 25mm below specimen A, 25mm left of specimen B
B/A	14	Separating element, 25mm below specimen A, 25mm right of specimen B
B	15	Separating element, mid-height of separating element, 25mm left of specimen B
B	16	Separating element, mid-height of separating element, 25mm right of specimen B

B	17	Separating element, 100mm above the bottom of the separating element, 25mm left of specimen B
B	18	Separating element, 100mm above the bottom of the separating element, 25mm right of specimen B
C/A	19	Separating element, 25mm below specimen A, 25mm left of specimen C
C/A	20	Separating element, 25mm below specimen A, 25mm right of specimen C
C	21	Separating element, 25mm above stitch plate, 25mm left of specimen C
C	22	Separating element, 25mm above stitch plate, 25mm right of specimen C
C	23	Separating element, 25mm left of the stitch plate, mid-height of the stitch plate
C	24	Separating element, 25mm right of the stitch plate, mid-height of the stitch plate
C	25	Gap seal, mid-width of the stitch plate, mid height of the stitch plate
C	26	Stitch plate, 25mm right of the left edge of the stitch plate, mid-height of the stitch plate
C	27	Stitch plate, 25mm left of the right edge of the stitch plate, mid-height of the stitch plate
D	28	Separating element, 25mm above service
D	29	Separating element, 25mm left of service
D	30	Ceramic wrap, top side of specimen, 25mm from sealant bead
D	31	Ceramic wrap, right side of specimen, 25mm from sealant bead
D	32	Steel pipe, top side of specimen, 25mm from end of ceramic wrap
D	33	Steel pipe, right side of specimen, 25mm from end of ceramic wrap
A	34	Separating element, 25mm below specimen A, mid-width of separating element
SE	35	Separating element

SE – separating element

8.2 Observations

Time Minutes	Test Face	SP#	Observations
10	E	ALL	Mastic has visibly combusted, discolouring and visible surface cracks
10	E	C	Mortar above stitch plate is visibly a lighter colour, discoloring between mortar and separating element
24	E	C	Visible white discolouring of mastic
24	E	D	Mastic has minor separation between specimen wrap and separating element
24	E	SE	Visible spots of spalling on the separating element, including the mortar ontop of stitch plate
30	E	B	Large visible expansion of mastic
45	E	C	Visible mastic combustion where stitch plate and mortar are located
50	U	D	Visible steam/moisture rising from the wrap
60	E	C	Where combustion of mastic had previously occurred, the mastic is beginning to fall away from the specimen, and the aperture is slightly recessed
75	E/U	ALL	No notable changes
90	U	B	Minor expansion of the mastic
105	E	D	Further separation and gap formation near mastic and specimen wrap junction
105	E	C	Gap forming along the top edge of the stitch plate mortar
105	E	A	Mastic separating from the separating element, top edge of gap seal
120	U	ALL	No notable changes
120	U	D	Moisture coming from wrap is no longer visible
120	E	C	Visible crack in the mastic near stitch plate
150	E/U	ALL	No notable changes

157	U	A, C	Visible expansion of the mastic
180	E/U	ALL	No notable changes
180	E	C	Gap near top of the stitch plate has opened further
207	U	C	Visible cracking and opening at the top left corner of the mortar junctions
210	E/U	ALL	No notable changes
215	U	A, B, C	Visible expansion of the gap seal
215	U	A, B, C	Bubbling of mastic which overlaps concrete separating element
240	U	A, B, C	Further expansion of mastic
240	E	C	Further visible gaps around mortar junction
240	E	SE	Visible white spots on the separating element
248	U	B	Lower half of the mastic has visible white discolouring
248	U	C	Discolouring between mastic joint and stitch plate
270	E/U	ALL	No notable changes
285	E/U	ALL	No notable changes
300	U	B	Mastic separating from concrete slab in three locations
300	U	A, B, C	Further expansion of mastic
300	E	SE	Increased number of white spots on separating element
315	U	B	Further separating of the mastic, both sides of the gap seal
330	U	A	Minor visible gas in mastic
330	E	D	Pipe wrap is deteriorating with visible break underneath
350	E	D	The break in the wrap has opened up further
360	E/U	ALL	No notable changes
360			TEST DISCONTINUED

Key: U = unexposed face. E = Exposed face.

9. Separating element and main fire-stopping system

The concrete Lintel (1.2) was fixed to the top of the refractory frame. 180mm thick concrete slabs were cut from a section of previously casted concrete. The concrete slabs were cut to a height of 1000mm, and arranged to create a 50mm (nominal) gap between slab 1 (1.3) and 2 (1.4), and a 30mm (nominal) gap between slab 2 and 3 (1.5). This resulted in a 40mm (nominal) gap between the top of the slabs and the concrete lintel. Prior to fixing the concrete slab, a 72mm hole was cut into slab 2. Once fixed in place, a 405mm x 305mm cavity was cut at the junction of slab 2 and 3, on both exposed and unexposed faces to allow for the stitch plate (1.6). The bottom of the stitch plate cavity was located 195mm from the bottom of slab 2. The cavity was cut to a depth of 45mm (nominal). Two holes were drilled into the stitch plate at mid-height of the plate, 50mm from each edge. The plate was placed in the cavity, and holes were marked on the concrete slabs to drill. Once drilled, a thin layer of mortar (3.2) was placed between the concrete slabs and the plate, then a M12 x 1.25 threaded rod and nuts were passed through both plates, and tightened, fixing the plates in place. The depth from the exposed and unexposed faces to the stitch plate was measured to be 35mm (nominal). The cavity on top of the stitch plate was filled using mortar, flush with the unexposed and exposed faces. The profile of the gap between slabs 2 and 3 was continued on top of the stitch plate, so mortar was removed to follow the gap seal.

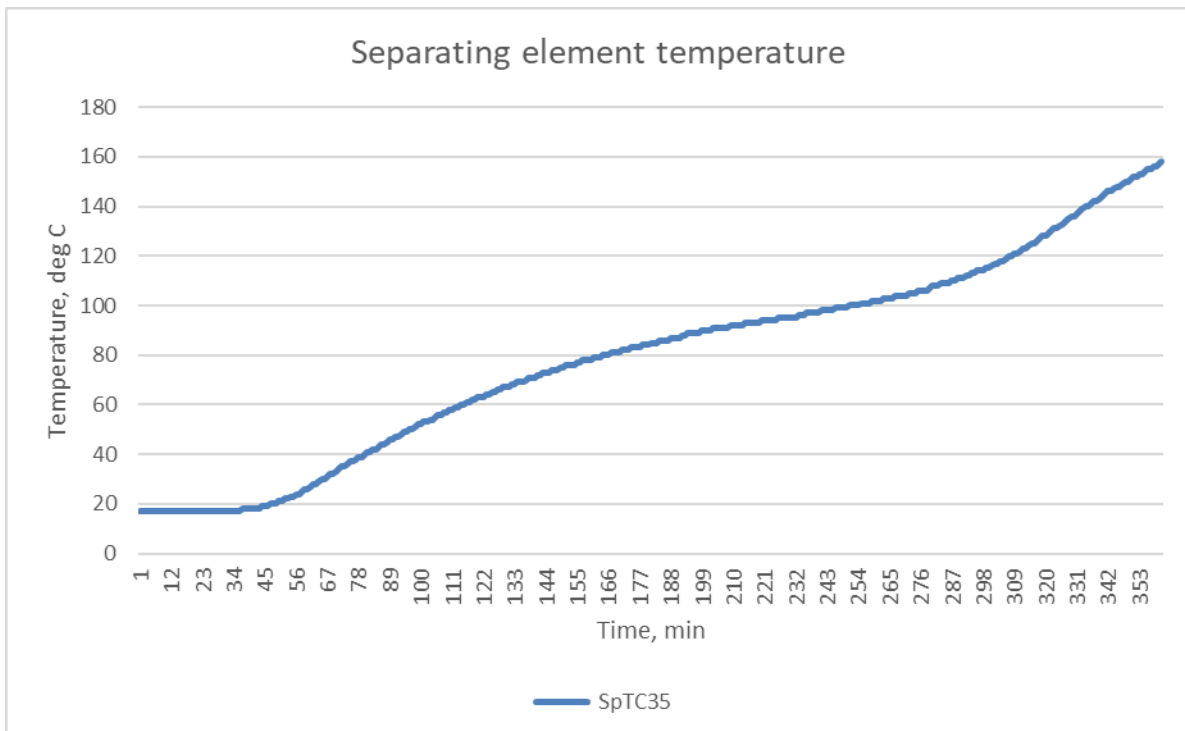

Unexposed face:



Exposed face:



10. Specimens

Unexposed faced:



Exposed face:



10.1 Specimen A

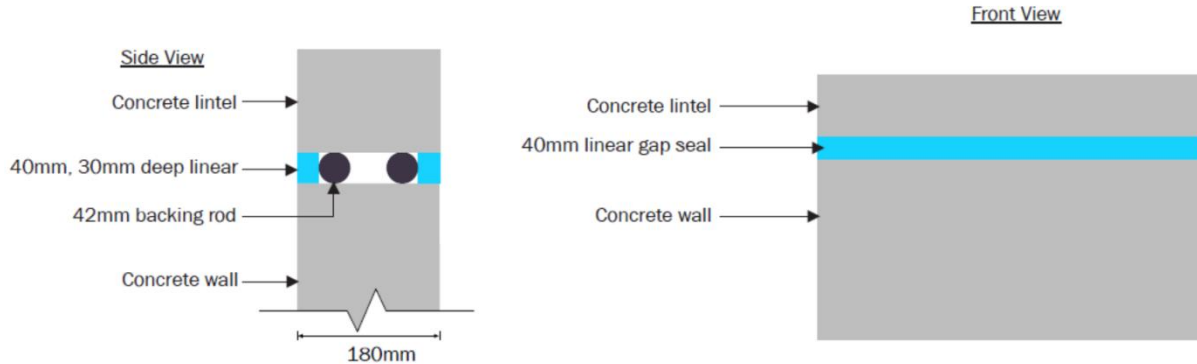

Penetration System		
A	Service	40mm linear joint
	Orientation	Horizontal
	Service Details	Concrete lintel (1.2), Concrete slab 1 (1.3), Concrete slab 2 (1.4), Concrete slab 3 (1.5), Sealant (3.1)
	Aperture Size	Width / Height (W/H): 1200mm x 40mm
	Local Fire-stopping Protection	
	Application	Symmetrical
Protection Used	Polystyrene backing rod was placed in aperture from both faces, recessed 30mm (nominal). A bead of mastic was placed on top of the backing rod, flush with the concrete slabs.	

Test results

Structural adequacy	Not applicable
Integrity	No failure at 360 min
Insulation	No failure at 360 min

Specimen A Thermocouples Readings

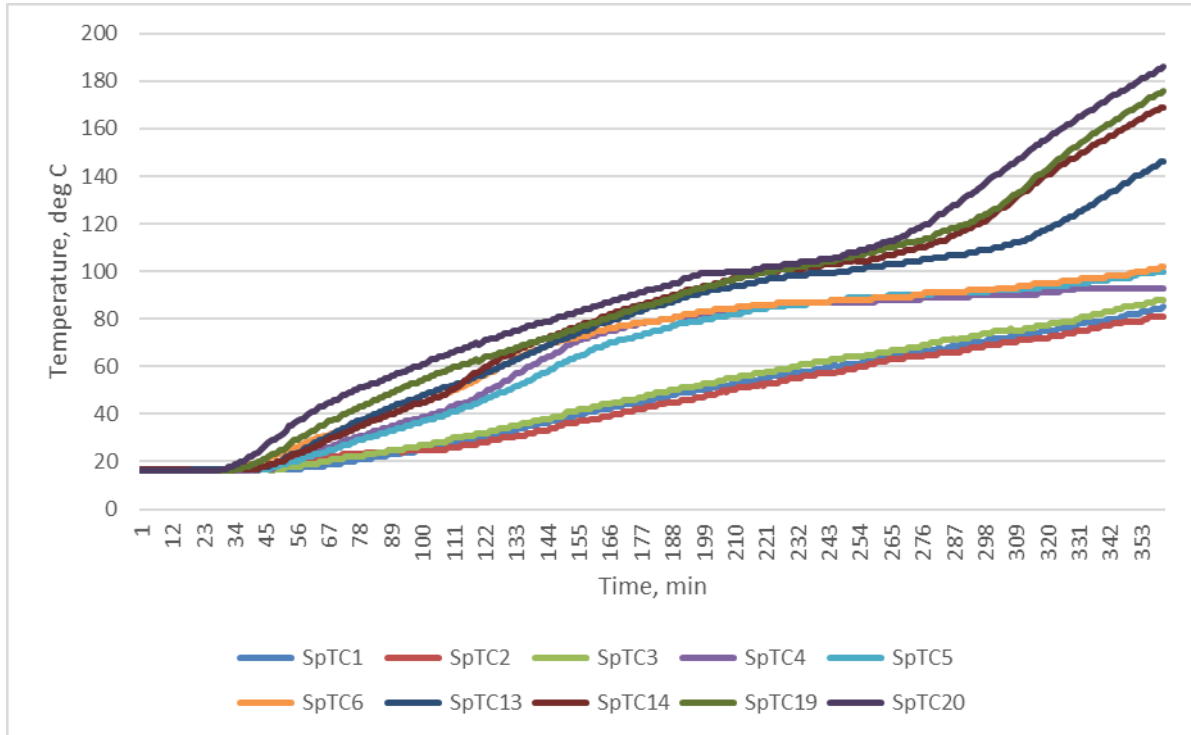

10.2 Specimen B

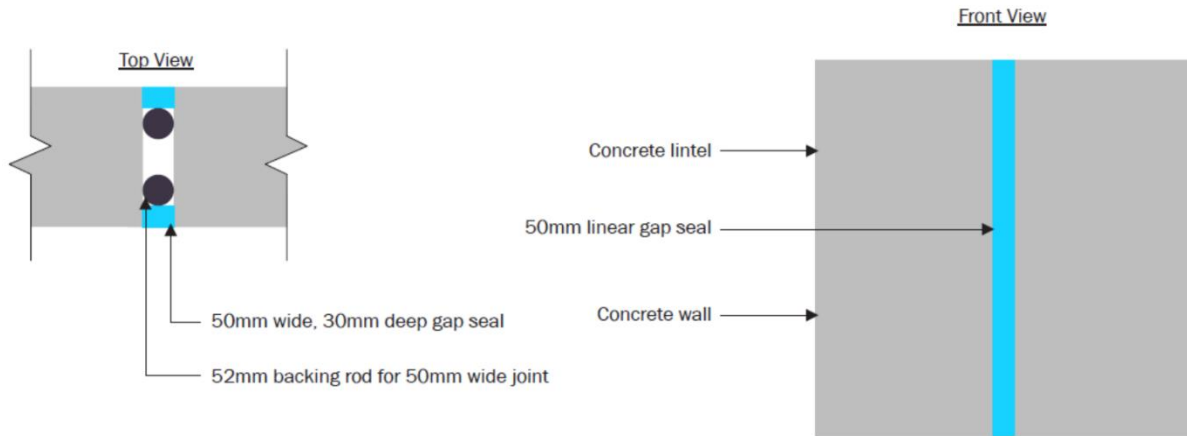

Penetration System		
B	Service	50mm linear joint
	Orientation	Vertical
	Service Details	Concrete slab 1 (1.3), Concrete slab 2 (1.4) Sealant (3.1)
	Aperture Size	Width / Height (W/H): 50mm x 1000mm
	Local Fire-stopping Protection	
	Application	Symmetrical
Protection Used	Polystyrene backing rod was placed in aperture from both faces, recessed 30mm (nominal). A bead of mastic was placed on top of the backing rod, flush with the concrete slabs.	

Test results

Structural adequacy	Not applicable
Integrity	No failure at 360 min
Insulation	No failure at 360 min

Specimen B Thermocouples Readings

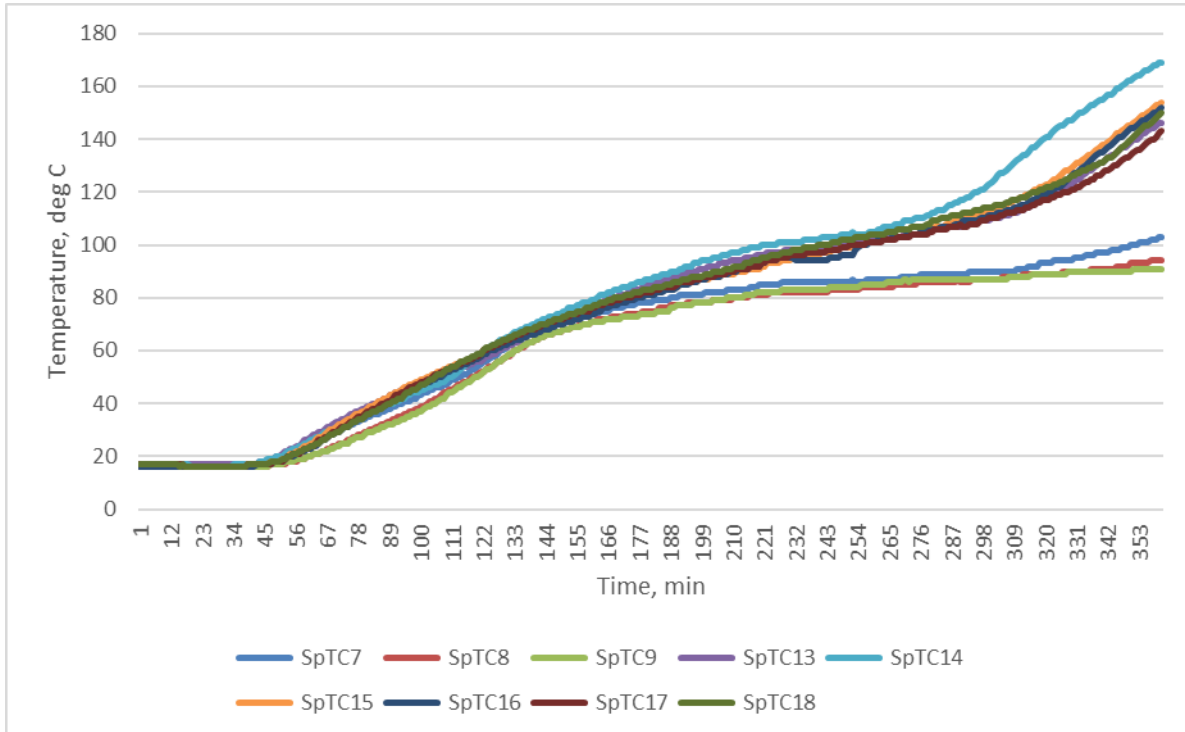

10.3 Specimen C

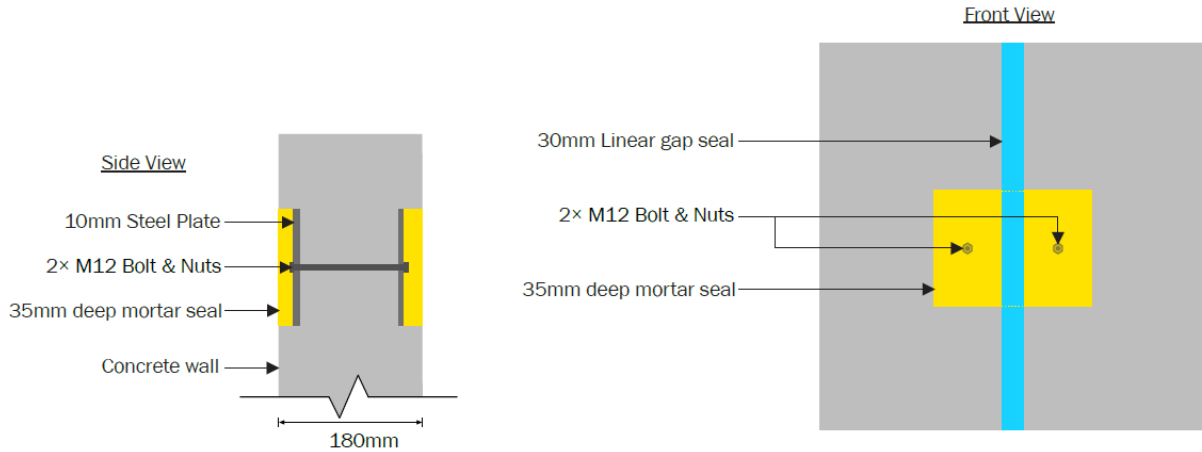

Penetration System		
C	Service	Stitch Plate Gap Seal
	Orientation	Horizontal
	Service Details	Concrete lintel (1.2), Concrete slab 1 (1.3), Concrete slab 2 (1.4), Concrete slab 3 (1.5), Sealant (3.1)
	Aperture Size	Width / Height (W/H): 1200mm x 30mm
	Local Fire-stopping Protection	
	Application	Symmetrical
	Protection Used	Polystyrene backing rod was placed in aperture from both faces, above and below the stitch plate, recessed 20mm (nominal). Polystyrene backing tape was placed on top of the stitch plate to ensure the depth was 35mm (nominal). A bead of mastic was placed on top of the backing rod, and on top of the stitch plate, flush with the concrete slabs. This resulted in a gap seal of 20mm along the length of the aperture, and a depth of 35mm along the stitch plate.

Test results

Structural adequacy	Not applicable
Integrity	No failure at 360 min
Insulation	No failure at 360 min

Specimen C Thermocouples Readings

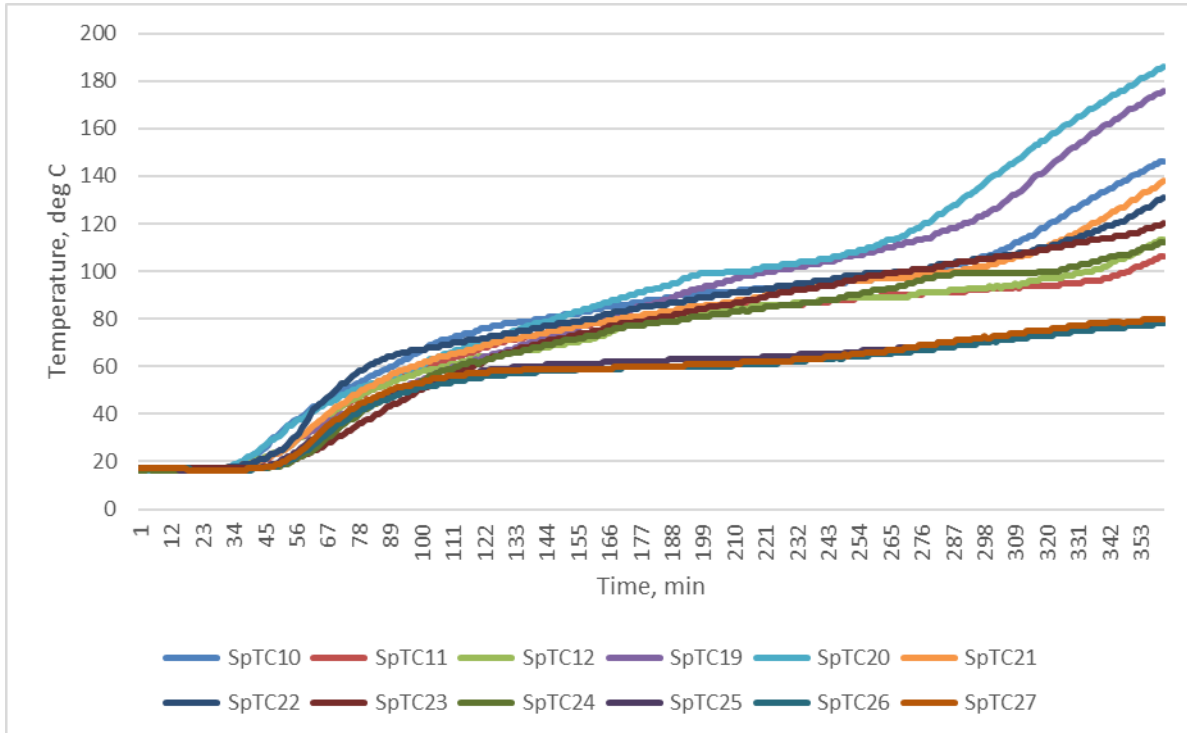

10.4 Specimen D

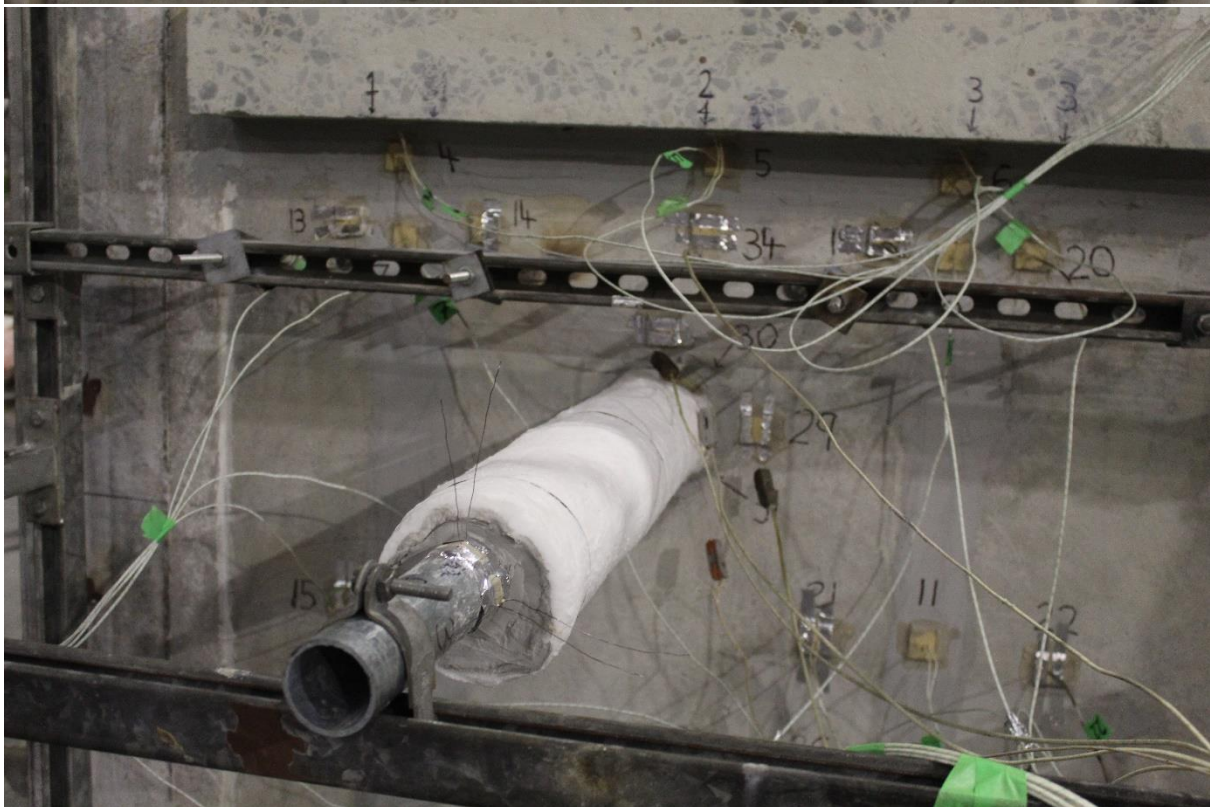

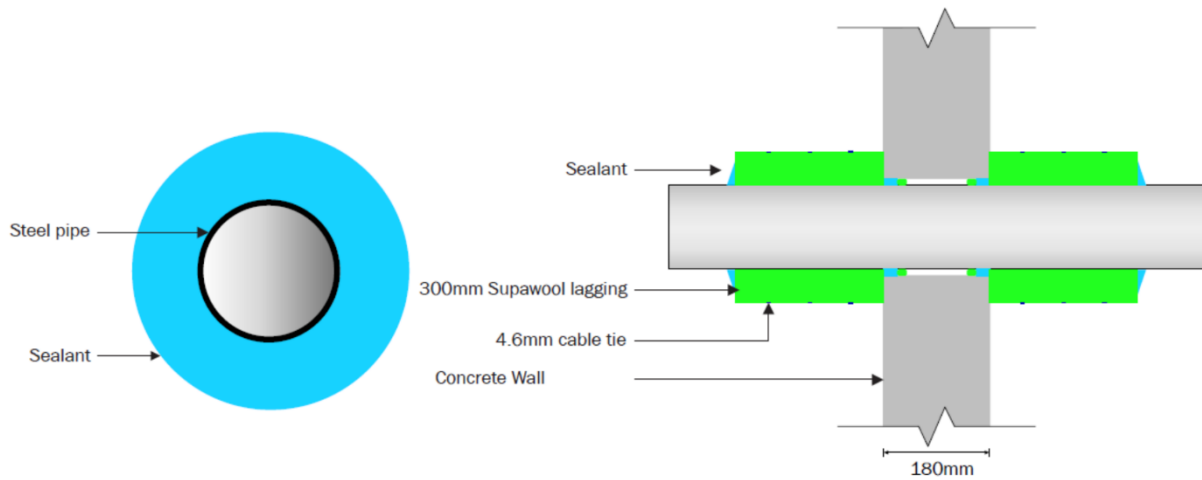

Penetration System		
D	Service	40DN Steel Pipe
	Service Details	Pipe (2.1), Sealant (3.1), Concrete slab 2 (1.4), Ceramic Fibre Blanket (5.1), Cable ties (4.3)
	Service Support	Unistrut structure at 500mm
	Aperture Size	72.27mm
	Annular Spacing	Min: 6mm, Max: 20mm
Local Fire-stopping Protection		
	Application	Symmetrical, capped from exposed face only
	Protection Used	<p>The steel pipe (2.1) was passed through the aperture, extending 850mm from both faces.</p> <p>Ceramic fibre backing was installed in the aperture, recessed 30mm (nominal) from both faces. Sealant (3.1) was applied to the apertures, flush with the separating element. A length of Ceramic fibre was cut and wrapped around the service 2 ¼ times. The ceramic fibre was secured using cable ties (4.3), and extended 610mm from both faces. A 25mm (nominal) radius bead of sealant was applied between the concrete slab and ceramic fibre. Sealant was applied between the end of the ceramic fibre and the pipe to fill any remaining gaps.</p>

Test results

Structural adequacy	Not applicable
Integrity	No failure at 360 min
Insulation	No failure at 360 min

Specimen D Thermocouples Readings

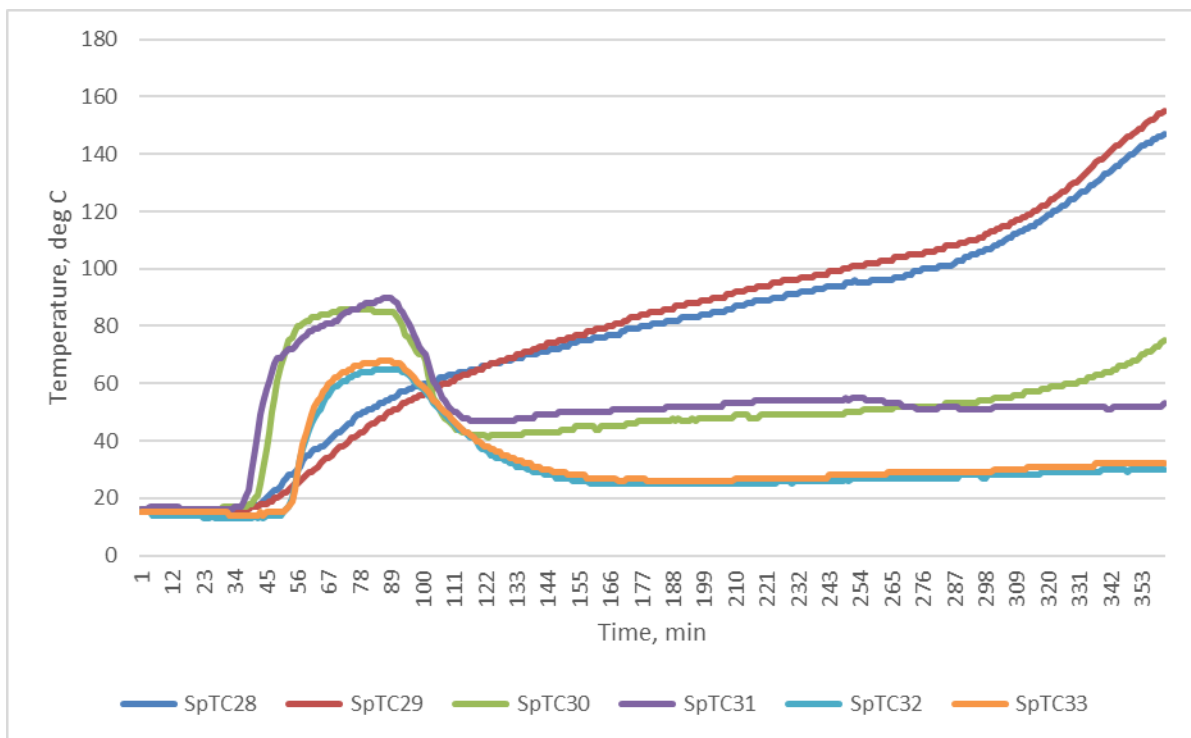

11. Additional photographs

11.1 Materials used



Item 3.1

11.2 During and after the test

30 minutes:

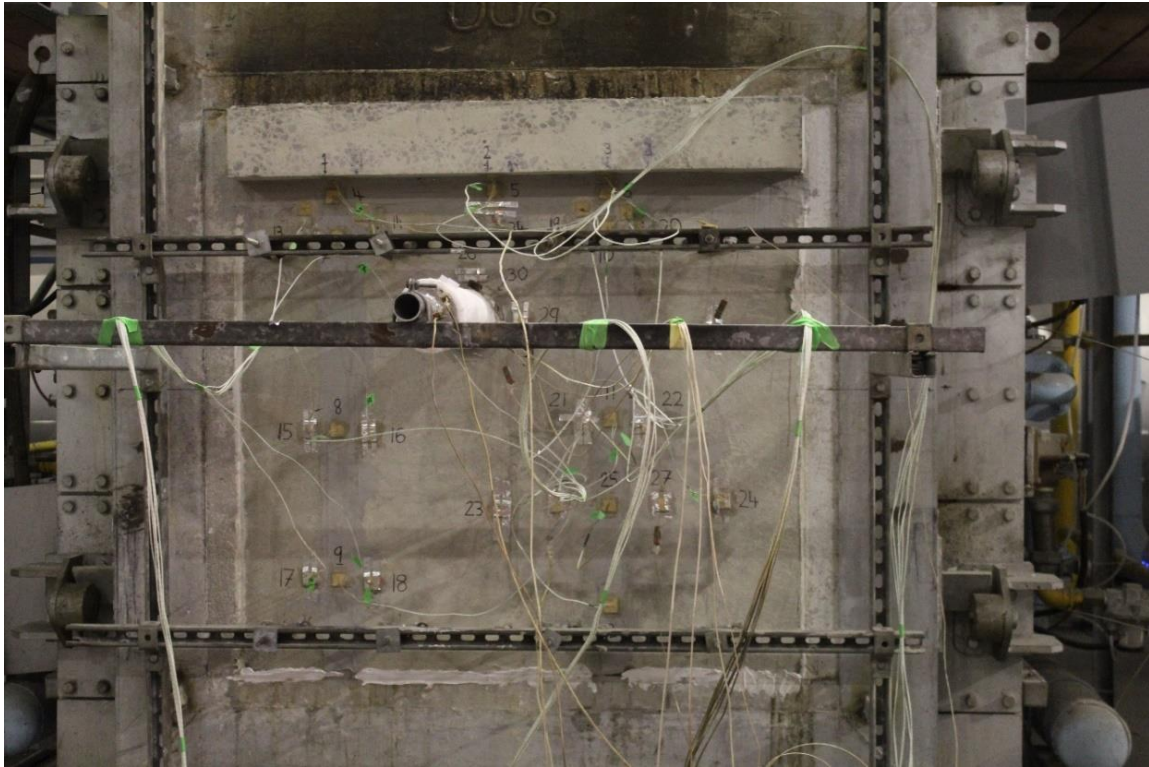

60 minutes:

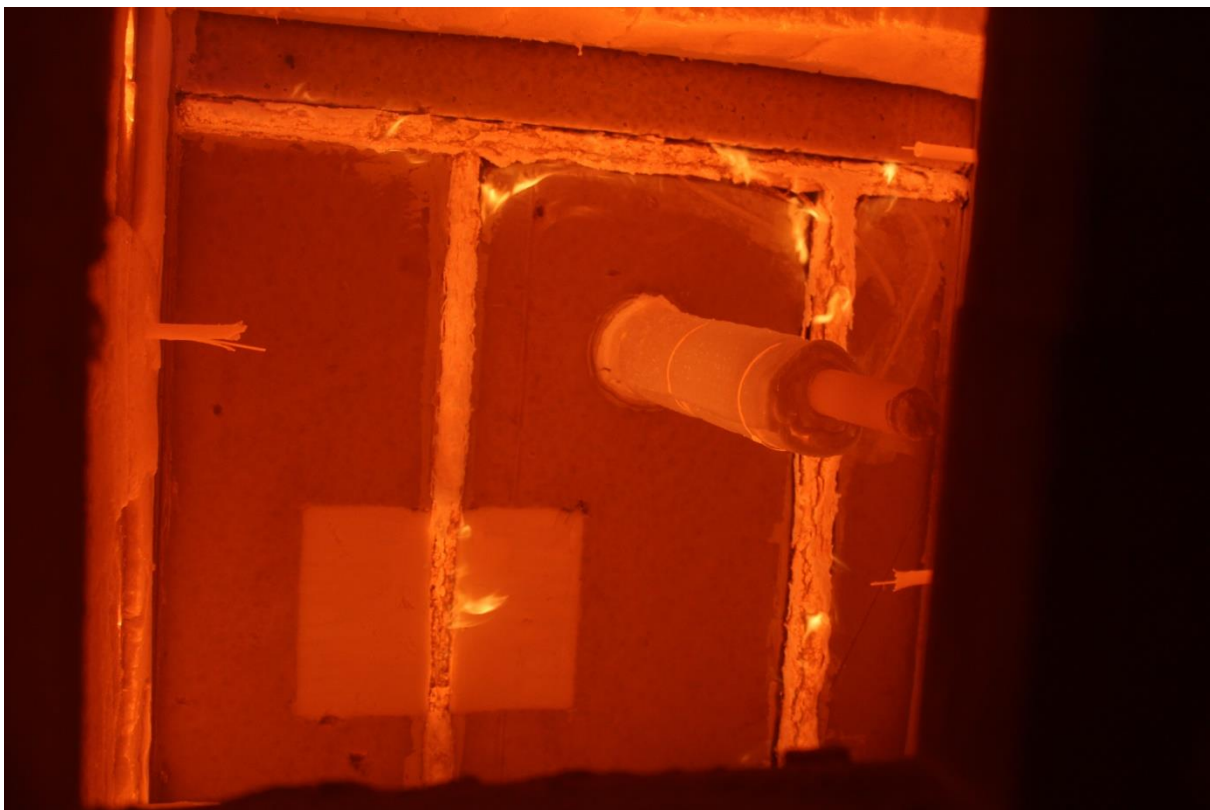
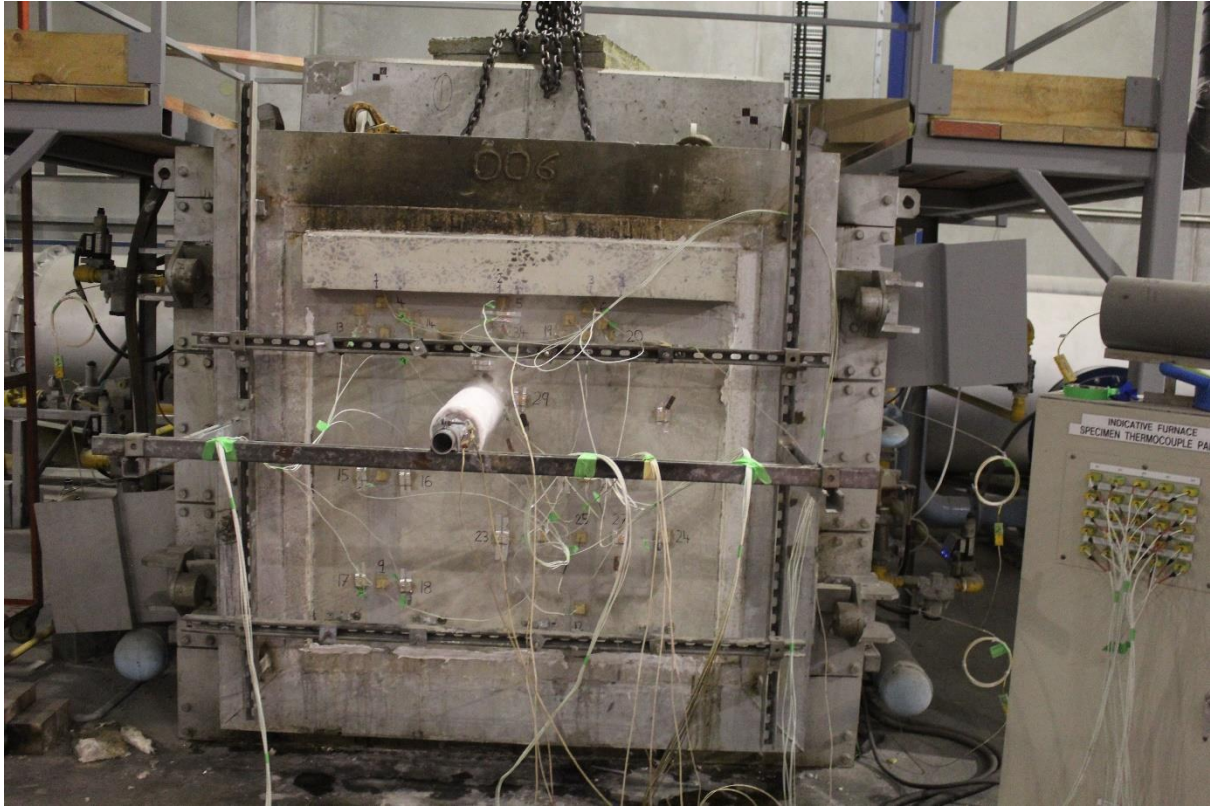

120 minutes:

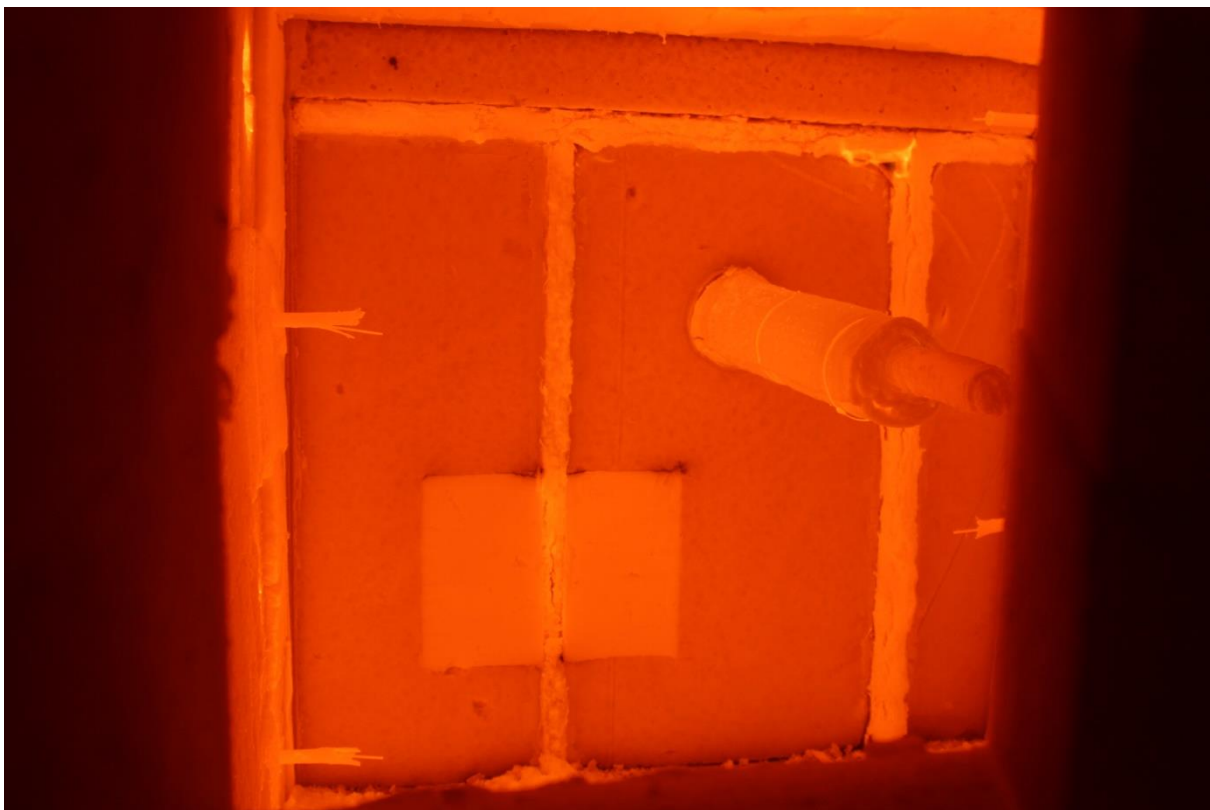

180 minutes:

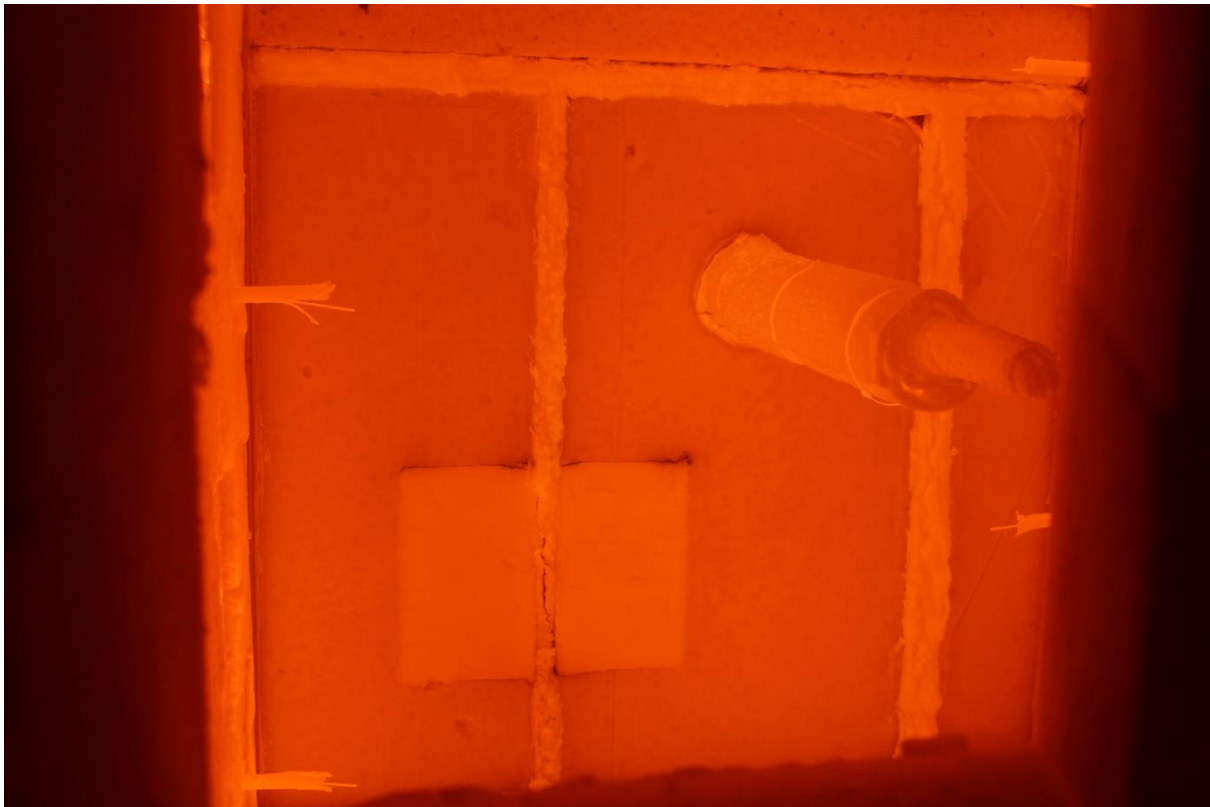

240 minutes:

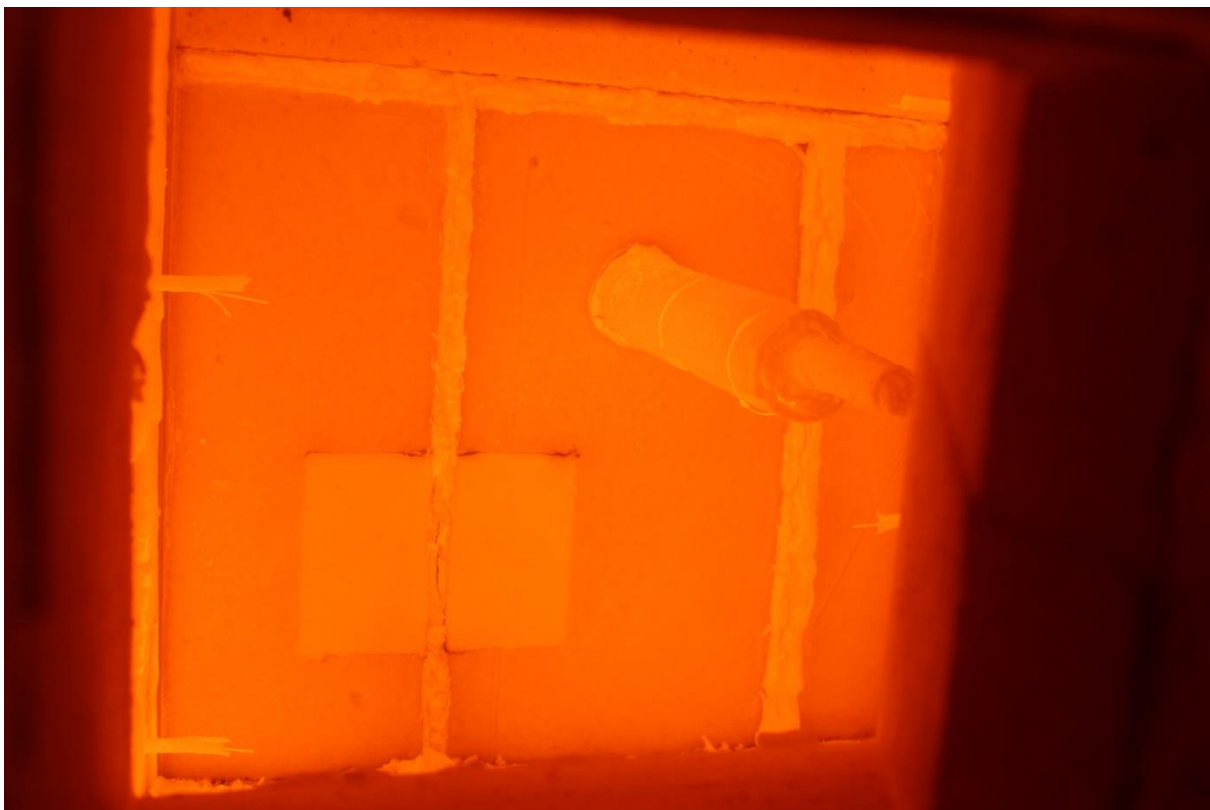

300 minutes:

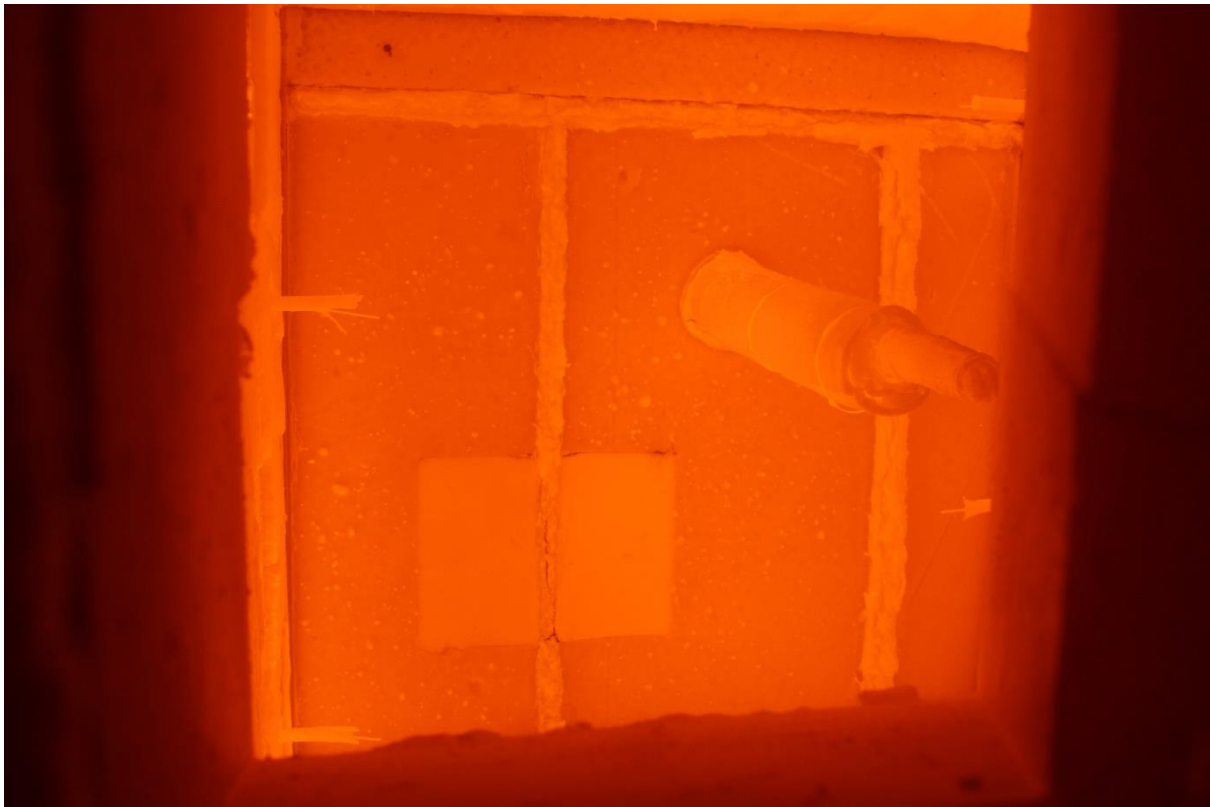

360 minutes:

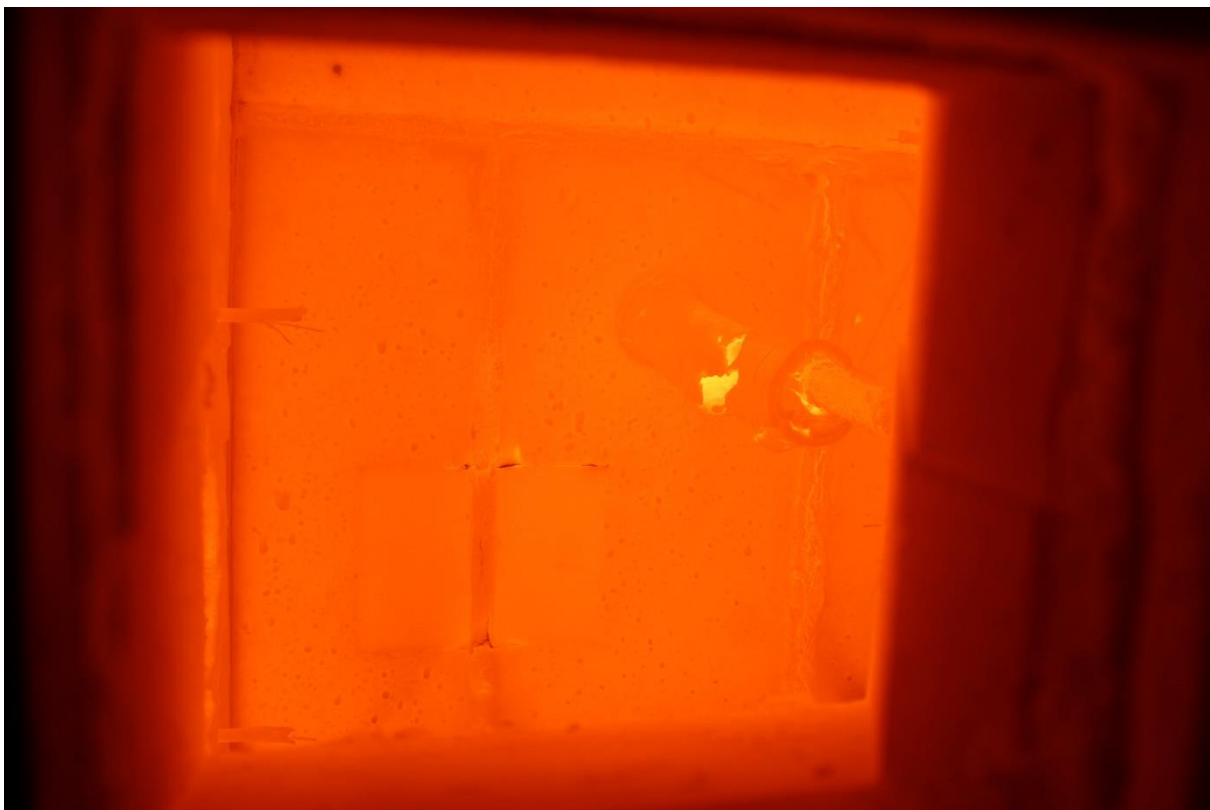
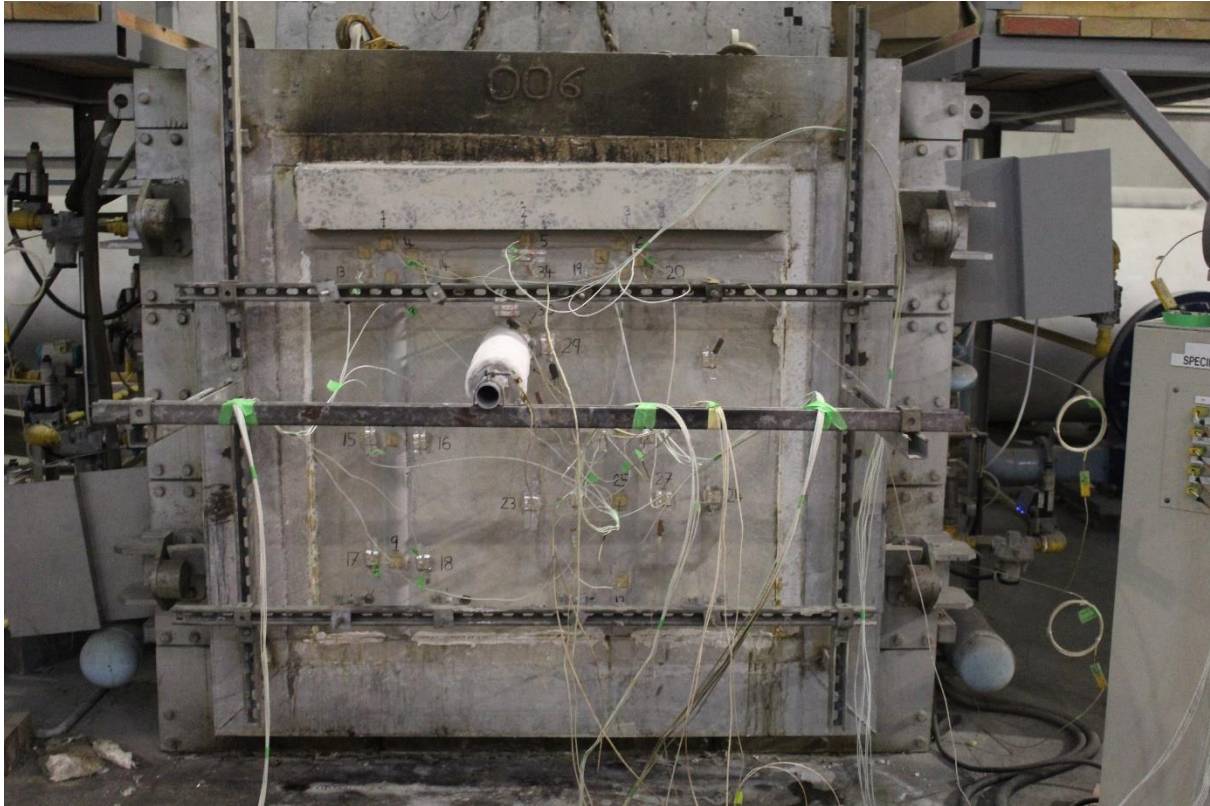

After the test:

